

APOLLO modena curved technical specification

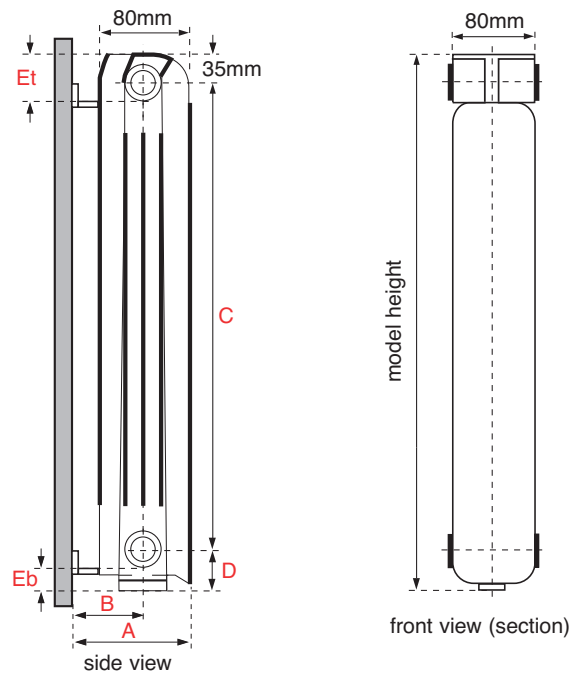

MODENA CURVED DIMENSIONS (mm)							
MODEL HEIGHT			430	580	680	780	880
Width of radiator			(No. of sections x 80) + 20				
Section depth			80	80	80	80	80
Section width (Panel + space)			80	80	80	80	80
Wall to front of rad		(A)	115	115	115	115	115
Wall to pipe centres	Side entry	(B)	75	75	75	75	75
	Bottom entry		N/A	N/A	N/A	N/A	N/A
Tapping centres	Side entry	(C)	350	500	600	700	800
	Bottom entry		N/A	N/A	N/A	N/A	N/A
Pipe centres	Side entry	(D)	45	45	45	45	45
	Bottom entry		N/A	N/A	N/A	N/A	N/A
Bracket positions	Top	(Et)	55	55	55	55	55
	Bottom	(Eb)	25	25	25	25	25
Tappings			1/2"	1/2"	1/2"	1/2"	1/2"

MODENA CURVED WEIGHTS AND VOLUMES (per section)					
Model height mm	430	580	680	780	880
Dry weight (A) Kg	1.06	1.42	1.55	1.86	2.04
Water content (B) Litres	0.28	0.36	0.40	0.45	0.49
Working weight (A+B) Kg	1.34	1.78	1.95	2.31	2.53
Outputs: Watts $\Delta T=50k$	86	115	131	149	163

The thermal outputs expressed at $\Delta T=50k$ comply with European regulation EN 442-2

ADDITIONAL INFORMATION	
Material	Aluminium alloy UNI 5076-74
Alloy thickness	0.8 to 2mm
Maximum working pressure	10 bar/1000 kPa
Mechanical strength test pressure	16.90 bar/1690 kPa
Maximum working temperature	75/80°C

TEMPERATURE			
FACTORS FOR DIFFERENCES BETWEEN MEAN WATER TEMPERATURE AND ROOM TEMPERATURE IN °C AND °F OTHER THAN 50 °C (90 °F)			
5 °C	0.050	10 °F	0.057
10 °C	0.123	20 °F	0.142
15 °C	0.209	30 °F	0.240
20 °C	0.304	40 °F	0.348
25 °C	0.406	50 °F	0.466
30 °C	0.515	60 °F	0.590
35 °C	0.629	70 °F	0.721
40 °C	0.748	80 °F	0.858
45 °C	0.872	90 °F	1.000
50 °C	1.000	100 °F	1.147
55 °C	1.132	110 °F	1.298
60 °C	1.267	120 °F	1.454
65 °C	1.406	130 °F	1.613
70 °C	1.549	140 °F	1.776
75 °C	1.694		

TO APPLY THE FACTORS SHOWN IN THE TABLE TO OUR QUOTED OUTPUTS. MULTIPLY THE QUOTED OUTPUT BY THE CHOSEN OPERATING FACTOR TO GIVE THE OUTPUT